

Specifications	X2204 KV1800		
Stator Diameter	定子外径	22mm	
Stator Thickness	定子厚度	4mm	
No. of Stator Arms	定子槽数	12	
No. of Rotor Poles	转子极数	14	
Motor Kv	电机KV值	1800	
No-Load Current (A/10V)	空载电流	0.2A	
Motor Resistance	电机电阻	156mΩ	
Max Continuous Current	最大连续电流	12.5A/15S	
Max Continuous Power	最大连续功率	140W	
Weight	重量 (含长线)	19.6g	
Rotor Diameter	转子直径	27mm	
Shaft Diameter	出轴直径	3mm	
Body Length	电机长度	20.4mm	
Overall Shaft Length	电机含轴总长度	21.1mm	
Max Lipo Cell	最大电池节数	2-3s	
ESC	建议使用电调	12A	
Recommended Prop(inch)	推荐螺旋桨规格	GWS8040	GWS8043
		GWS9047	GWS9050

AEROBATIC(适用特技机重量) 200g (2S 8040\8043)

适用3D机重量 155g 2S GWS9047\9050\8040\8043

Prop (inch)	Volts (V)	Amps (A)	Thrust (gf)	Watts (W)	Efficiency (g/W)	Load temperature in 100% throttle 全油门负载温度
GWS8040	7.4	1.4	100	10.36	9.652509653	65°
		2.3	150	17.02	8.813160987	
		3.4	200	25.16	7.949125596	
		4.5	250	33.3	7.507507508	
		6	300	44.4	6.756756757	
		7.5	350	55.5	6.306306306	
		8.4	380	62.16	6.113256113	
	11.1	1	100	11.1	9.009090909	
		1.6	150	17.76	8.445945946	
		2.5	200	27.75	7.207207207	
		3.5	250	38.85	6.435006435	
		4.5	300	49.95	6.006006006	
		5.6	350	62.16	5.630630631	
		7	400	77.7	5.148005148	
GWS9047	7.4	1.4	100	10.36	9.652509653	48°
		2.5	150	18.5	8.108108108	
		3.6	200	26.64	7.507507508	
		5.1	250	37.74	6.62427133	
		6.4	300	47.36	6.334459459	
		8	350	59.2	5.912162162	
		10	410	74	5.540540541	
GWS9050	7.4	1.3	100	9.62	10.3950104	55°
		2.2	150	16.28	9.213759214	
		3.3	200	24.42	8.19000819	
		4.6	250	34.04	7.344300823	
		6.1	300	45.14	6.645990253	
		8.1	350	59.94	5.839172506	
		10.2	400	75.48	5.299417064	
		12	450	88.8	5.067567568	
GWS8043	7.4	1.4	100	10.36	9.652509653	44°
		2.5	150	18.5	8.108108108	
		3.7	200	27.38	7.304601899	
		5	250	37	6.756756757	
		6.5	300	48.1	6.237006237	
		8.1	350	59.94	5.839172506	
		10	410	74	5.540540541	

Notes: The test condition of temperature is motor surface temperature in 100% throttle while the motor run 10 min.

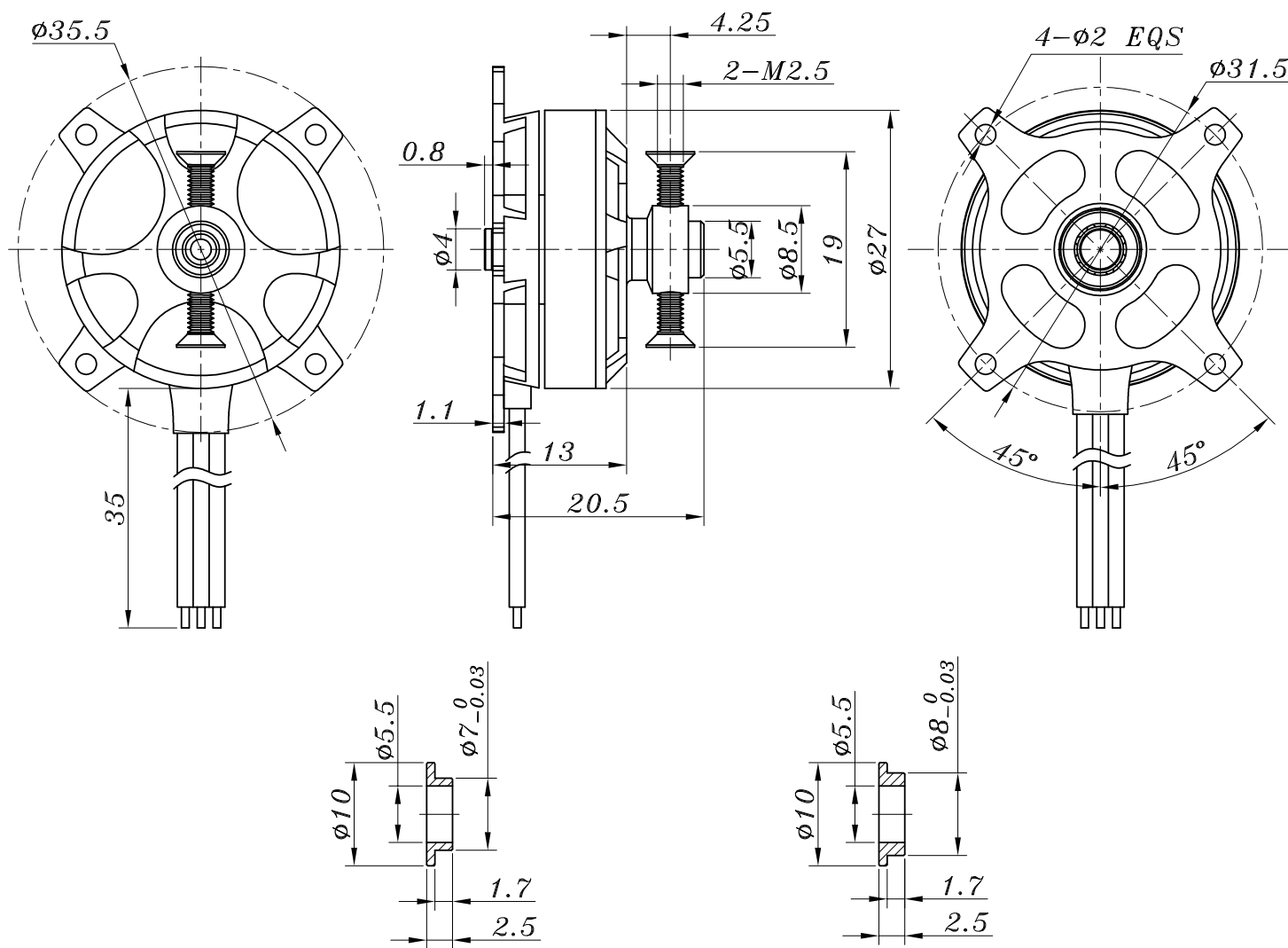

配件/Accessories